

**Display of Registration Marks**  
Report by Head of Ranger Services

**Purpose:** This report consults the Committee on the Authority's current policy regarding the display of registrations marks and in particular the position regarding the requirement for the river cruiser class to display the marks on the stern of the vessel.

**1. Background to Byelaw 16**

- 1.1. The Broads Authority Vessel Registration Byelaws (1997), Byelaw 16 (Display of Marks) states:

*'No person shall moor, use or navigate a vessel on waters within the navigation area or cause or permit a vessel to be so moored, used or navigated unless the current registration mark issued by the Authority in respect of the vessel is conspicuously displayed at all times on both sides of the vessel near the bow and on the stern of the vessel.'*

This wording followed the guidance provided by Port and Haven Commissioners that the "*plates they supply should be fixed in three places, namely on each side of the bow and on the stern*" for the 1930 Byelaws.

- 1.2. The clear display of the unique registration mark for a vessel, a combination of letters and numbers, is essential for the Rangers to be able to quickly identify it in carrying out their duties, for example enforcing the Authority's speed limit byelaws and determining whether a valid toll has been paid. They are also important for members of the public so that they can identify a vessel for example when reporting an incident. Boats on the Broads also have names, but these are not unique, and it is the registration marks that provide the identification of every boat on the Broads.
- 1.3. In 1998, when the new Registration Byelaws were first being implemented, a guidance document was developed setting out the detailed arrangements for the display of the registration marks to take account of the wide variety of craft using the Broads. This document was widely consulted on before being adopted and published. A number of concessions were agreed over the size, location and type of display for specific classes of craft. Correspondence with users relating to this consultation made it clear by the Authority that the display of the toll plaque was an important part of being able to agree to these arrangements.

- 1.4. Whilst toll plaques were being displayed the requirements in the guidance document were not rigidly enforced and the Authority has been aware that a relatively small number of owners of vessels have never correctly displayed registration marks. However, now the requirement to display a toll plaque has been removed, the need to be able to quickly and easily identify a vessel from its registration mark becomes critical in being able to check whether the appropriate toll has been paid. This was highlighted to the Navigation Committee when discussing the move to a paperless tolls system. As a result of making the decision to remove the requirement to display a tolls plaque, the Authority asked Rangers to enforce the requirements in the “Display of Registration Marks” guidance document.
- 1.5. Media articles explaining this change in approach to registration marks have been produced in the last two copies of toll payer newsletter the “*Broadsheet*”. Each year a copy of the “Display of Registration Marks” guidance booklet is sent out to every boat owner when a toll is paid.

## **2. Enforcement**

- 2.1. As with all the Broads Byelaws, Rangers must take a fair and consistent approach when enforcing them. This has meant some owners of vessels which had never properly displayed a registration mark (although required to in the guidance) have now been asked to do so. To help facilitate this change, Rangers have been speaking to boat owners when out on patrol to explain why the Authority will now be looking to enforce the proper display more thoroughly.
- 2.2. During the 2018/19 season Rangers issued Notices of Contravention to boat owners whose vessels were not displaying their registration marks correctly. Notices in respect of 436 vessels have been issued, almost all in private ownership. Given the size of the private fleet at over 10,000 vessels, this amounts to about 4% and therefore involves a relatively small proportion of boat owners. There is a particular issue regarding sailing cruisers for which 165 notices have been issued, representing around 15% of the fleet. Motor vessels have been issued with the highest number of notices (212) representing 3% of all motor boats.
- 2.3. Many of the owners who have been issued with notices for non-display of registration marks have complied with the request and displayed their numbers.

## **3. Current Guidance**

- 3.1. A copy of the current guidance is contained in Appendix 1. Members will see that it lists all the categories of vessel and specifies the location and size for the display of the registration marks.
- 3.2. In discussion with representatives of the Norfolk & Suffolk Boating Association (NSBA) and the Norfolk and Suffolk Broads Yacht Owners Association (NSBYOA), the following concerns have been raised:

- (i) Lack of consistency of the arrangements in the guidance document being given to the different boating classes and between hire and private boats, for example hire half-deckers and keel boats have to display the marks on the stern, private boats of the same class do not;
- (ii) Large number of categories making it difficult for boat owners to understand how to comply;
- (iii) The requirement for the river cruiser class to display a registration number on the stern of the vessel when half deckers and keel boats are only required to display their name. Similarly hire half deckers are required to display a registration number on the stern.

The NSBA and NSBYOA would like the guidance to be reviewed and have made some specific suggestions on how it could be improved.

- 3.3. Regarding items (i) and (ii), officers have reviewed the guidance document, the comments from the NSBA and the options available. They are of the view that while some minor improvements could be beneficial to the document, for example combining categories 1 and 2 for private and hire motor cruisers which have the same requirements, this is not a pressing matter which would justify revising the present document before its distribution to all boat owners in the new tolls year.
- 3.4. Regarding item (iii), this is a contentious issue about the requirement for the river cruiser class to display registration numbers on both the bow and the stern. For clarity, it is permitted for sailing cruisers to have the smaller 50 mm size mark and it is not required to use the plaques provided by the Authority.
- 3.5. The Ranger team has worked hard over the last season to gain compliance and increase the understanding of this issue amongst boat owners. The vast majority of boaters have already responded to the notices and complied with the requirement to display registration numbers. Officers fear that boaters may feel aggrieved by any deviation from the current requirement.
- 3.6. The NSBA has proposed that the requirement for the river cruiser class to display the registration marks on the stern should be removed. This is not supported by officers. On the contrary, in the absence of a requirement to display a toll plaque, there is if anything a case for tightening up the guidance such that a wider range of private sailing boats conform more closely to the requirements stated in the byelaws to display the marks "*on both sides of the vessel near the bow and on the stern of the vessel*". However, a review of the guidance is not a current priority. Furthermore, the considerable time and effort that would be required reopening engagement on this issue with user groups, committees and the wider boating community would be significant.
- 3.7. In summary, it is assessed that it is not a priority to review the current guidance regarding the three points brought forward by the NSBA and NSBYOA.

## 4. Rowing

- 4.1. Rowing vessels (racing craft as opposed to rowing dinghies) were not included in the original guidance document. Most rowing vessels have no stern and slope downwards at the bow making display of mark difficult. All rowing vessels registered with British Rowing (the National Governing Body for rowing) are required to display their unique BR alphanumeric number.
- 4.2. This number needs to be 6cm high and of contrasting colour and displayed on the Saxboard.



Photo showing BR number (in this case **CUW204**) displayed on a rowing vessel.

- 4.3. The requirement to display a BR number applies to the majority of rowing vessels on the Broads. For rowing vessels registered with British Rowing, it is proposed to require them to display only their BR number. The Authority will have a record of this number and be able to trace a registered owner in the same way we do with the Broads registration number. Clubs are also required to maintain a register. For other craft without a BR number, it is proposed for the requirement to be to display the BA registration number on the Saxboard (50mm height). This system has been trialled on the Broads for the past 2 seasons. The Rowing clubs (representing the vast majority of this type of vessel) have recently been consulted on the trial and agree that this system represents the clearest way forward for identification of rowing vessels on the Broads. If the Committee support this approach it is proposed to include this in a reprinting of the Guidance document for 2020.

## 5. Next Steps

- 5.1 The officer view is that the current guidance on the display of registration marks should be retained for 2019, and that a section on rowing vessels is added to the 2020 guidance. It is their view that the immediate priority is to enforce compliance with the byelaws using the existing guidance.
- 5.2 To that end officers would like the views of the Committee on two options:
  - (i) proceeding with enforcement action for those boats already identified as failing to comply with the byelaw; or,
  - (ii) providing a further reminder of the need to comply with the guidance in the February Broadsheet and to give all boat owners until the end of April to

comply before taking further enforcement action. This would be prior to the first main Ranger inspection of the year in May when they check that tolls are paid and boat marks displayed.

Background papers: None

Author: Lucy Burchnall/Rob Rogers  
Date of report: 18 December 2018

Appendix: Appendix 1 – Display of Registration Marks Guidance

# Display of registration marks

Ref: Broads Authority Vessel Registration Byelaws 1997

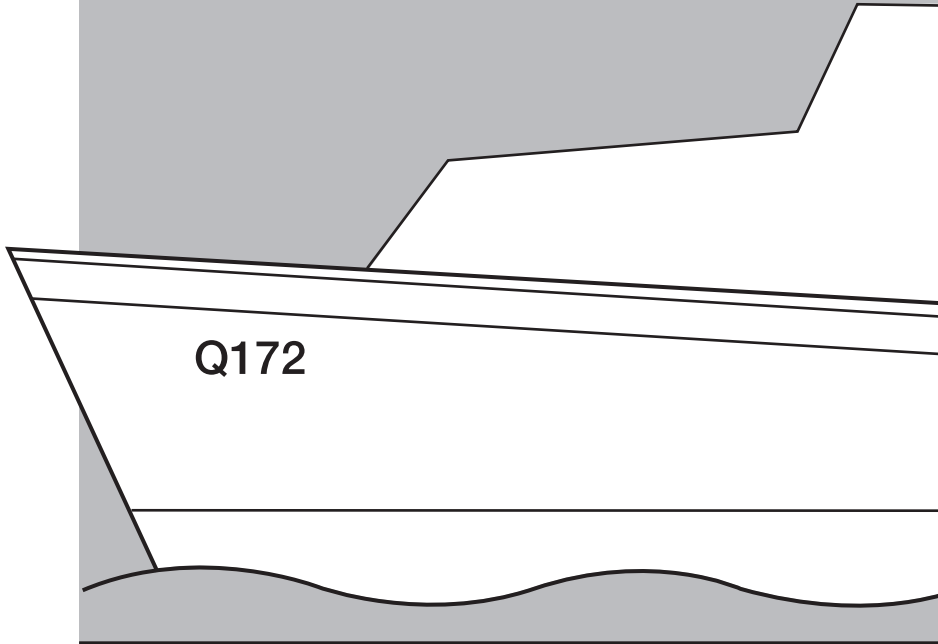

Tolls Office, Broads Authority, Yare House,  
62-64 Thorpe Road, Norwich NR1 1RY  
tel: 01603 610734 email: [tolls@broads-authority.gov.uk](mailto:tolls@broads-authority.gov.uk)

**Tolls direct 01603 756080**

[www.broads-authority.gov.uk](http://www.broads-authority.gov.uk)



**Broads**  
Authority

The **Broads Authority Vessel Registration Byelaws 1997** require that every vessel moored, used or navigated in the Authority's Navigation Area or adjacent waters must be registered with the Authority and that the registration marks issued by the Authority must be conspicuously displayed on the vessel. The byelaws also require that the appropriate toll for the vessel must be paid. Failure to comply with these requirements is an offence which may lead to conviction and a fine of up to £1,000.

## Registration Marks

The Authority issues three self-adhesive registration mark plaques per vessel. Alternatively plainly and conspicuously painted registration marks or screw on numbers are permitted. Characters must be plain, not stylised, and must be applied on a contrasting background.

The registration marks must be of the correct size, that is 90 mm (3½") for motor cruisers and most powered craft, 50 mm (2") for sailing craft. Display requirements for various types of craft are set out overleaf. Replacement numbers are available from the Authority's head office. There is a charge for this.

The registration mark remains with the vessel until it is destroyed or permanently removed from the Broads.

**Do not remove the registration mark on sale of the vessel.**

*Fix adhesives to a clean dry surface*

registration mark



## Display

Where display of registration marks is required "on both bows and on the stern" (see overleaf) they must be displayed on each side of the hull of the vessel within approximately 2 metres of the bow so as to be clearly visible from other vessels or the bank, and on the stern of the vessel so as to be clearly visible from behind.

Registration marks must not be wholly or partially obscured by fenders or fender lanyards or by dinghies in davits etc. It may be necessary to repeat the marks to avoid this.

Registration marks must not be displayed on the superstructure, cabin sides or upper-works of a vessel or in cabin or wheelhouse windows.

Yachts may display registration marks on a board securely suspended beneath the bowspit, visible both sides.

Vessels with permanent guard rails round the deck edge may display registration marks on boards securely mounted on the guard rails near the bow.

Where the registration mark is obscured by a protective cover (whether temporary or permanent) the cover must carry a facsimile of the registration mark clearly visible from both sides of the vessel.



## Registration marks

**1** HIRE  
**motor cruisers,**  
all sizes  
including  
passenger/  
excursion vessels

[90 mm] on both sides of vessel near bow and on stern

**2** PRIVATE  
**motor cruisers,**  
all sizes

[90 mm] on both sides of vessel near bow and on stern

**3** HIRE  
**motor dayboats,**  
**launches,**  
**motor dinghies,**  
all sizes -  
includes all  
motor craft let out  
for hire other  
than as tenders to  
larger hire craft -  
see category 10

[90 mm] on both sides of vessel near bow and on stern

**4** PRIVATE  
**motor dayboats,**  
**launches,**  
**outboard dinghies,**  
**dories etc.**  
including sailing  
dinghies/tenders  
fitted with  
outboard motors

**Length over 5.0 m (16.4')**

[90 mm] on both sides of vessel near bow and on stern

**Length 5.0 m (16.4') or less**

[50 mm] on both sides of vessel near bow and on stern

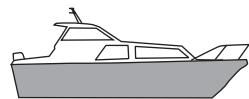
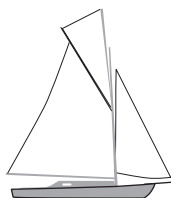
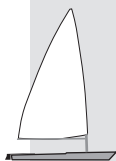

5 HIRE  
**sailing cruisers,**  
all sizes  
incl. half-deckers/  
keelboats

Note: All sailing  
vessels may display  
marks on a board  
beneath bowsprit,  
visible both sides.

[50 mm] on both sides of vessel near bow and on stern

6 PRIVATE  
**sailing cruisers,**  
all sizes

Note: All sailing  
vessels may display  
marks on a board  
beneath bowsprit,  
visible both sides.

As category 5 above **but:** vessels with a low freeboard or long counter stern which makes display impracticable will not be required to display marks **provided** the vessel is clearly marked on both bows or on stern with its registered name.

7 PRIVATE  
**half deckers/  
keelboats,**  
(e.g. YBOD, BOD,  
WOD, only)  
Rebel, Reedling,  
Yeoman, Squib,  
Flying Fifteen and  
traditional Broads  
half-deckers  
etc)

[50 mm] options:

- (a) on both sides near bow
- (b) on board beneath bowsprit, visible both sides
- (c) on cockpit coaming facing outboard, both sides
- (d) on foredeck, port and starboard, near deck edge

but display not required provided the vessel is clearly marked with its registered name on both bows or on the stern (or in the case of vessels with long counters on the aft cockpit coaming)

## Registration marks

8 PRIVATE

**sailing dinghies**, including those used for tuition commercially but which are not let out for unsupervised hire

Note: sailing dinghies fitted with outboard motors as for category 4.

[50 mm] options:

- (a) on both sides near bow
- (b) on tabernacle both sides
- (c) on stern of vessel facing outboard provided clearly visible and never obscured by covers etc. while vessel is afloat.

9 HIRE

**rowing/sailing/outboard dinghies**. Includes all dinghies let out for hire as tenders to larger hire craft. Excludes all powered dinghies let out for independent or unsupervised hire, for which see category 3.

[50 mm] options:

- (a) on both sides near bow
- (b) on transom facing outboard,
- (c) on transom inboard provided clearly visible and never obscured by covers etc. while vessel is afloat.

10 PRIVATE

**rowing dinghies**, including non-powered tenders to larger craft

[50 mm] options:

- (a) on both sides near bow
- (b) on transom facing outboard,
- (c) on transom inboard provided clearly visible and never obscured by covers etc. while vessel is afloat.

11 PRIVATE  
canoes, kayaks

[50 mm] options:

(a) one set on port side of vessel near bow.

(b) one set in front of helm, across the deck and readable from the bow.

British Canoeing members are not required to display registration marks but their membership card must be carried at all times and produced on request.

12 sailboards,  
paddle boards

[50 mm] across the board near the bow readable from the bow

13 river  
maintenance  
craft  
including  
mud wherries,  
crane pontoons,  
piling rigs, tugs etc.

[90 mm] on forepart of vessel visible both sides and on stern of vessel so as to be visible from astern.

14 HIRE & PRIVATE  
houseboats  
stationary/  
non-powered

Display not required provided name of vessel clearly displayed on either side.

